

REV.	DESCRIPTION	DRAWN	CHECKED	APPROVED
A	NEW RELEASE	JLZ 11/25/17'		

NOTES:

- SPECIFICATIONS:
  - CONTACT RESISTANCE:30mΩ max.
  - INSULATOR RESISTANCE:1000MΩ min.AT DC 500V.
  - CURRENT RATING:1.5A.
  - VOLTAGE RATING:30VDC.
  - DIELECTRIC STRENGTH:AC 500V FOR 1 Minute.
- MATERIALS:
  - HOUSING:PBT+30% GLASS FIBER(UL 94 V-0).
  - CONTACT:COPPER ALLOY
  - SHELL:STEEL.
- ENVIRONMENT CHARACTERISTICS:
  - TEMPERATURE: -20°C~+85°C.

4. PRODUCT NUMBER CODE:

DS1096 - X X X X

- SHELL TYPE
  - S: W/ shrapnel
  - X: W/O shrapnel
- CONTACT Plating
  - 0: Selective Gold flash
  - 03: Selective Gold 3u"
  - 30: Selective Gold 30u"
- SHELL Plating
  - N: Nickel
  - 6: Tin
- COLOR OF HOUSING:
  - W: WHITE
  - B: BLACK

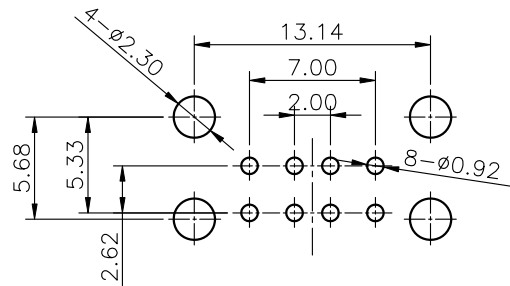
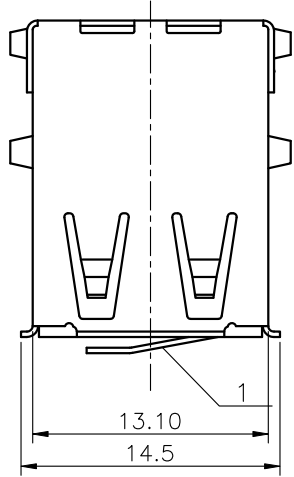

RECOMMEND PCB LAYOUT  
TOLERANCE=±0.05

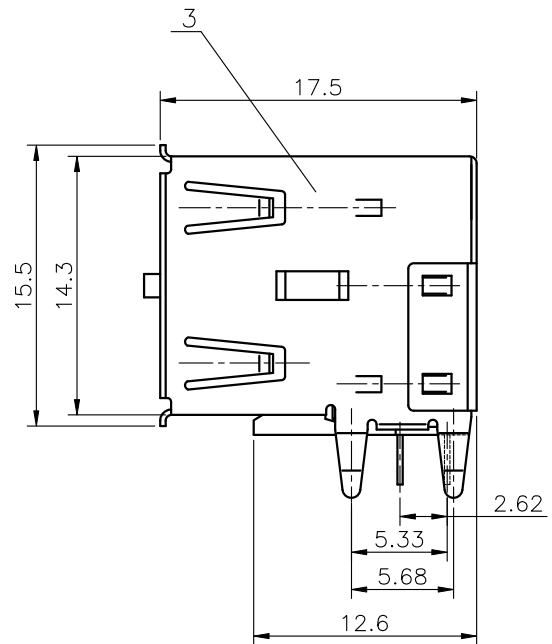
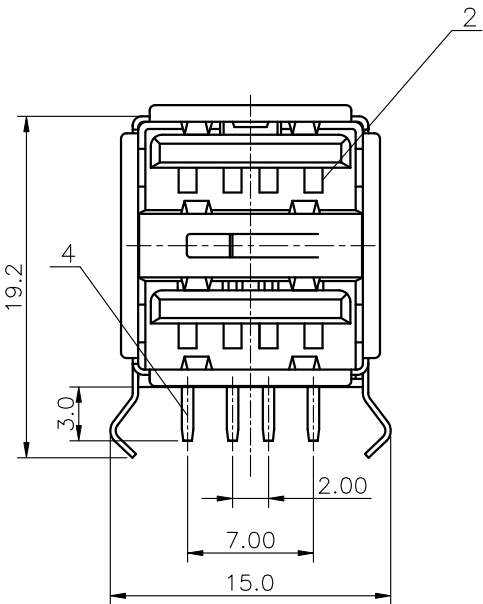

GENERAL TOLERANCE		ANGLE TOLERANCE		PROJECTION		TITLE	USB DUAL 8 PIN RECEPTALCE RIGHT ANGLE TYPE		
X.	±0.60	X.	±5°	UNITS	mm	SHEET SIZE	A4	SERIES	DS1096 SERIES
.X	±0.38	.X	±3°						
.XX	±0.25	.XX	±2°						
4	CONTACT	COPPER ALLOY	SEE NOTES	DRAWING TYPE		CUSTOMER			
3	SHELL	STEEL	SEE NOTES	SCALE	1:1	SHEET	1 OF 1		
2	HOUSING	PBT	UL 94 V-0	DRAWING NO.	C-DS1096-XXXX-A				
1	SHRAPNEL	STEEL	Nickel Plated	<b>晨翔电子有限公司</b> <b>CONNFLY CONNFLY ELECTRONIC CO. LTD</b>					
ITEM	PART NAME	PART NO.	MATERILAS						

晨翔电子有限公司  
CONNFLY CONNFLY ELECTRONIC CO. LTD